

Anti-Spark Module

SEPS Safety E-Power Switch-Retail

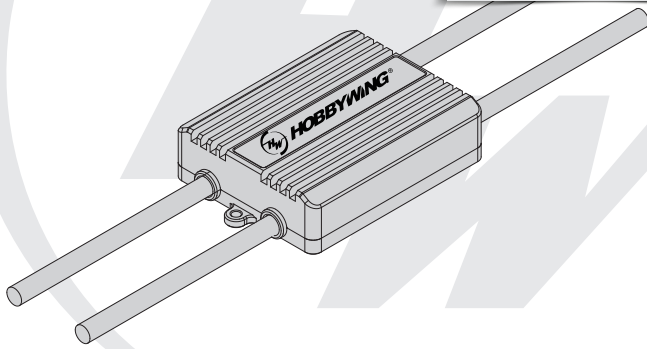

20190925

Thank you for purchasing this HOBBYWING product! The use of high-power devices can be dangerous, any improper use may cause personal injury and damage to devices, so please make sure to read through this manual before use and strictly abide by the prescribed operating procedures. We are not liable for any liability arising from the use of this product or the unauthorized modification of the product, including but not limited to, incidental or indirect losses.

01 Introduction

The anti-spark module has anti-spark function when connect it to power supply, which effectively protect plugs, power supply and electronic devices. The aluminium alloy dentate heat sink design of shell can better dissipate heat and reduce working temperature. Internal glue filling and packaging technology. The waterproof grade up to IP67.

02 Features

- The anti-spark module can be connected to 200A current continuously under the condition of 5m/s wind speed dissipation heat, supporting 18-61V power supply voltage.
- The 5 m/s wind speed heat dissipation and anti-spark module can be connected to use unlimited times under normal service life, which is more advantageous than anti-spark plug.
- It can completely eliminate sparks if connect the anti-spark module plug and delay 4S to switch on (There is slight sparks when connect anti-spark plug)

03 Specifications

Product name	Voltage	Max. Current	Input line specification	Output line specification	Weight	Size
SEPS Safety E-Power Switch-Retail	18-61V (Must be used within the voltage range)	200A (5m/s wind speed dissipation heat)	8AWG	8AWG	240g	86*59*21mm

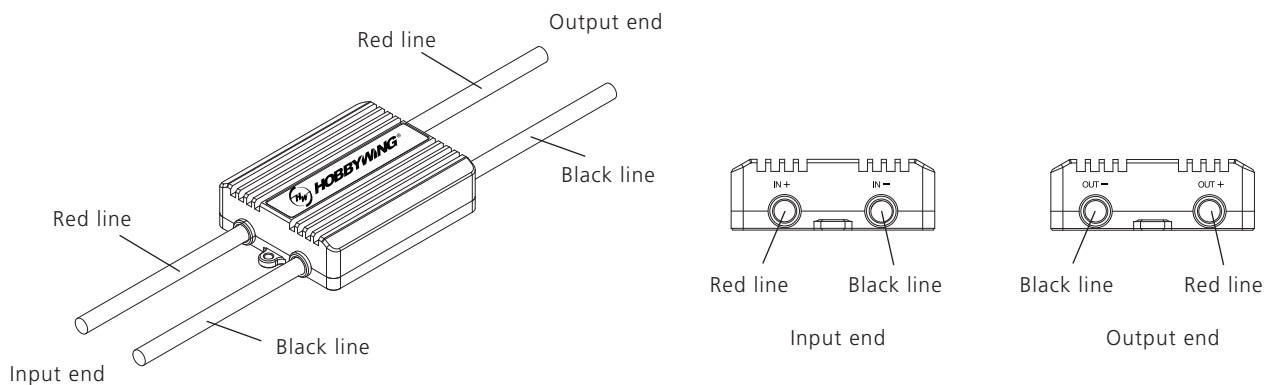

04 Connection mode

Note: Please use high-power welding equipment to weld power line, and ensure the reliable grounding of the welding equipment.

Wiring diagram:

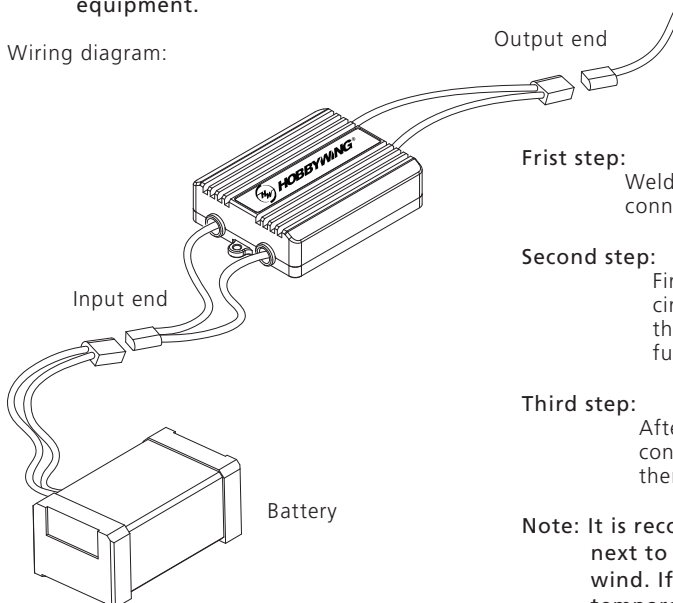

Frist step:

Weld plug for input end and output end of anti-spark module to connect power supply and load equipment.

Second step:

Firstly connect the output end of anti-spark module with distributor circuit or ESC load (Must connect anti-spark module and load first, then connect anti-spark module and battery can realize anti-spark function.)

Third step:

After all the connections and takeoff preparations are completed, connect battery to anti-spark module to supply power for the drone, then the drone can take off at any time.

Note: It is recommended that the anti-spark module would be better placed next to the battery or outside the drone to dissipate heat in the wind. If use anti-spark module for a long time and its shell temperature reaches 110°C, please reduce power to use, otherwise the anti-spark module will be burnt and power off.